



### 2.5.2 Series PL/PLF

#### Where used

In conveyors used to transport very corrosive materials and where difficult working conditions prevail: the extraction industries and in the mining of salt, chemical industries, fertiliser manufacture and in marine environments which require corrosion resistant rollers.

These rollers demonstrate particular resistance to the presence of high humidity and water, and also to corrosive elements present in the environment or in the conveyed material itself.

The design of the rollers utilises plastic materials for the most critical parts, which, excellently and economically, substitute for traditional materials such as stainless steel, bronze and aluminium.

Testing and actual plant trials have well demonstrated the efficiency and versatility of these rollers.

The characteristics designed into them provide a long working life even in the most severe environment, and when one considers their low purchasing and maintenance cost, PL/PLF rollers provide the ideal solution for severe applications.

The functioning temperatures recommended are:

-10° to +50°C for PL rollers

-10° to +70°C for PLF rollers





## 2 Rollers

### series PL-PLF



#### Characteristics

The PL roller has been designed with two important principles: to offer the maximum resistance to a corrosive environment, together with mechanical properties sufficient to sustain heavy loads on the belt conveyor or caused by the material being conveyed.

The first characteristic has been achieved utilising, for all the external parts of the roller, materials resistant to corrosion.

The second, is the design of the roller itself as a precision arrangement and generously dimensioned (whether it is the thickness of the load carrying parts or in the items in contact with the belt).

The result of this intelligent design has made possible a roller very resistant to the environment and to chemicals and aggressive materials, and at the same time of surprising lightness, optimum balance and quietness, that also reduces energy consumption thanks to the avoidance of any contact parts in the sealing system.

#### Roller shell

Comprises a precision high quality rigid PVC tube of a large thickness resistant to low and high temperatures.

In the PLF version the tube shell is in steel machined at either end, to allow the insertion of the bearing housings.

#### Bearing housings

They are produced by a high pressure moulding of polypropylene loaded with fibreglass.

This material gives high resistance to corrosion as well as an optimum mechanical resistance.

The endcap is forced with an interference fit into the counterbored section of the tube to present an united structure that is very robust, light, flexible and above all shock resistant.

#### Spindles

Diameter 20 mm in drawn steel and ground to guarantee at optimum fit to the bearing.

#### Bearings

Radial rigid precision bearings with a spherical ball race, series 6204 and internal play C3 fit.

#### Seals

Internally we find a labyrinth seal which brushes against the spindle to protect the bearing from eventual condensation or rusting from the interior of the tube where it is in steel.

The tube when in plastic does not rust and having a good thermic insulation limits the formation of condensation.

The patented external protection is made from anti-corrosive material: polypropylene loaded with glass fibre, similar to the end cap.

#### Resistance to chemical agents

Agents	Polypropylene (PP)	Polyvinyl chloride (PVC)
Grease, oil	○	○
Petrol	○	○
Strong alkalines	○	○
Weak alkalines	○	○
Strong acids	◻	▲
Weak acids	▲	○
Hydrocarbons	◻	▲
Organic acids	○	○
Alcohol	○	○
Ketone	◻	●

○ resistant      ▲ in general sufficiently resistant  
● non resistant      ◻ resistant only in certain conditions

The seal presents a front cover shield, that prevents the ingress to the body of items larger than 0.5 mm.

The particular self cleaning geometry of the end cap facilitates the rejection of fine particles by the action of gravity, even when the roller is inclined, meanwhile the centrifugal action of the roller rotation aids the cleaning process when material arrives in the proximity of the end cap.

The labyrinth is very deep and divided into two zones separated by a large chamber, which lengthens the route for and protects the bearing from the ingress of foreign particles.

The wall of the labyrinth on the bearing side is formed in a manner that increases the grease chamber. The type of grease is lithium based water repellent and anti-rusting, providing lubrication for long roller life.

The table indicates the diameter of rollers in production. The diameters are those standards according to European unification to norm DIN (for steel body).

Upon request rollers may be supplied with lengths and spindle extensions according to norms CEMA, BS, JIS, AFNOR, ISO-FEM and UNI.

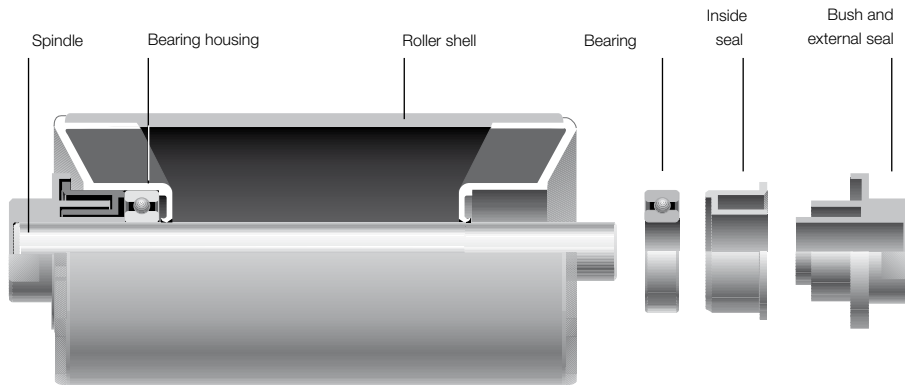

**Programme of production series PL & PLF**

roller type	Ø mm	basic design	s	spindle d	ch	bearings	note
PL 2	90	V	4,3	20	30	6204	with tube in rigid PVC, colour grey RAL 7030, spindle steel S235JR (Fe360, DIN St37) slotted bushes in polypropylene fiber glass charged
	110	V	5,3				
	140	V	8,5				
PL 3	90	V	4,3	20	14	6204	with tube in rigid PVC, colour grey RAL 7030, spindle steel S235JR (Fe360, DIN St37) slotted bushes in polypropylene fiber glass charged
	110	V	5,3				
	140	V	8,5				
PL 4	90	V	4,3	20	14	6204	with tube in rigid PVC, colour grey RAL 7030, spindle steel S235JR (Fe360, DIN St37) with flats ch14
	110	V	5,3				
	140	V	8,5				
PLF 1	89	N	3	20	30	6204	with tube and spindle in steel S235JR (UNI Fe360, DIN St37) bushes in polypropylene fiber glass charged
	108	N	3,5				
	133	N	4				
PLF 5	89	N	3	20	14	6204	with tube and spindle in steel S235JR (UNI Fe360, DIN St37) bushes in polypropylene fiber glass charged
	108	N	3,5				
	133	N	4				
PLF 20	89	N	3	20	14	6204	with tube and spindle in steel S235JR (UNI Fe360, DIN St37)
	108	N	3,5				
	133	N	4				

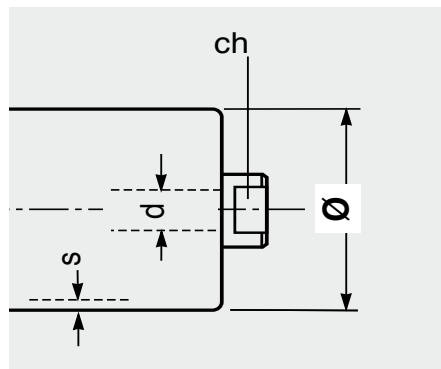



## 2 Rollers

series

**PL 2**

**PL 3**

**PL 4**

**Ø 90 V**

Bearing 6204  
(20 X 47 X 14)

### PL 2

d = 20  
d<sub>1</sub> = 35  
ch = 30  
s = 4,3  
e = 4  
g = 10

### PL 4

d = 20  
d<sub>1</sub> = 20  
ch = 14  
s = 4,3  
e = 4  
g = 10

### PL 3

d = 20  
d<sub>1</sub> = 20  
ch = 14  
s = 4,3  
e = 4  
g = 10

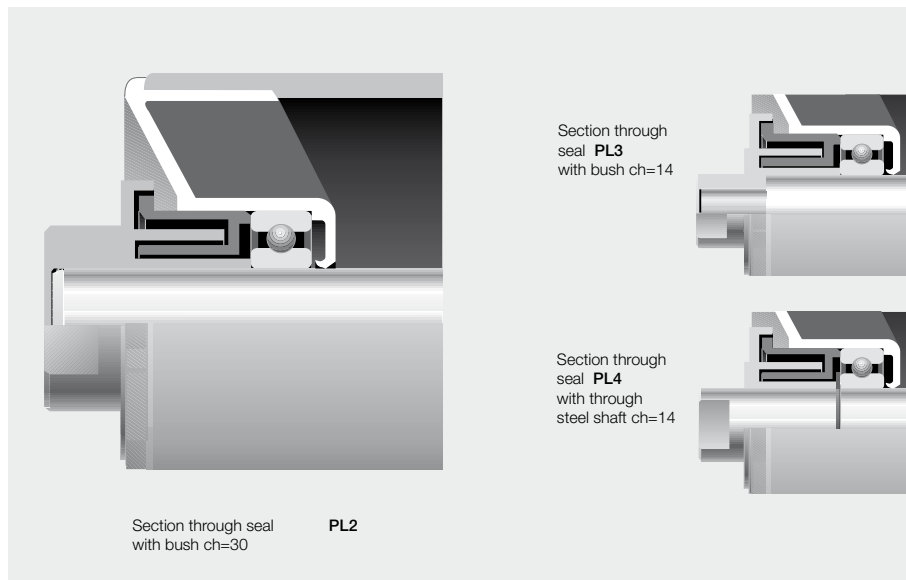

belt		roller										
width mm	arrangements	dimensions mm			weight Kg		load capacity daN					
		B	C	A	rotating parts	total	belt speed m/s					
							1	1.25	1.5	1.75	2	2.5
400		160	168	188	0.7	1.2	97	88	80	75	70	63
500		200	208	228	0.8	1.3	97	88	80	75	70	63
400	650	250	258	278	0.8	1.5	97	88	80	75	70	63
500	800	315	323	343	1.0	1.8	97	88	80	75	70	63
650	1000	380	388	408	1.1	2.1	97	88	80	75	70	63
800	1200	465	473	493	1.2	2.4	97	88	80	75	70	63
400		500	508	528	1.3	2.6	97	88	80	75	70	63
500	1000	600	608	628	1.5	3.0	97	88	80	75	70	63
	1200	700	708	728	1.6	3.4	97	88	80	75	70	63
650		750	758	778	1.7	3.6	97	88	80	75	70	63
800		950	958	978	2.1	4.5	50	50	50	50	50	50
1000		1150	1158	1178	2.4	5.3	28	28	28	28	28	28
1200		1400	1408	1428	2.8	6.3	16	16	16	16	16	16

The indicated load capacity relates to a project working life of 10,000 hours.

**Example of ordering**  
standard design  
PL2,20N,90V,323

for special design  
see pages 80-81

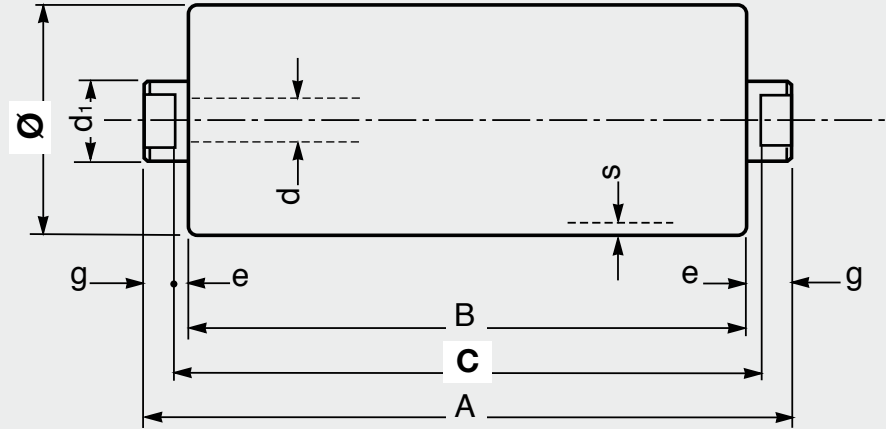
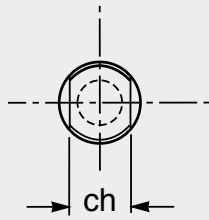

## Ø 110 V

Bearing 6204  
(20 x 47 x 14)

### PL 2

d = 20  
d<sub>1</sub> = 35  
ch = 30  
s = 5,3  
e = 4  
g = 10

### PL 4

d = 20  
d<sub>1</sub> = 20  
ch = 14  
s = 5,3  
e = 4  
g = 10

### PL 3

d = 20  
d<sub>1</sub> = 20  
ch = 14  
s = 5,3  
e = 4  
g = 10

belt		roller			weight Kg		load capacity daN					
width mm		dimensions mm					daN					
arrangements 		B	C	A	rotating parts		belt speed m/s					
					parts	total	1	1.25	1.5	2	2.5	3
	400	160	168	188	1.2	1.6	107	96	88	77	69	64
	500	200	208	228	1.3	1.8	107	96	88	77	69	64
	400 650	250	258	278	1.4	2.1	107	96	88	77	69	64
	500 800	315	323	343	1.5	2.4	107	96	88	77	69	64
	650 1000	380	388	408	1.7	2.7	107	96	88	77	69	64
	800 1200	465	473	493	1.9	3.1	107	96	88	77	69	64
	400	500	508	528	2.0	3.3	107	96	88	77	69	64
	500 1000	600	608	628	2.2	3.8	107	96	88	77	69	64
	1200	700	708	728	2.5	4.3	107	96	88	77	69	64
	650	750	758	778	2.6	4.5	107	96	88	77	69	64
	800	950	958	978	3.1	5.5	107	96	88	77	69	64
	1000	1150	1158	1178	3.6	6.5	62	62	62	62	62	62
	1200	1400	1408	1428	4.2	7.7	35	35	35	35	35	35

The indicated load capacity relates to a project working life of 10,000 hours.

**Example of ordering**  
standard design  
PL2,20N,110V,473

for special design  
see pages 80-81



## 2 Rollers

series

**PL 2**

**PL 3**

**PL 4**

**Ø140 V**

Bearing 6204  
(20 X 47 X 14)

**PL 2**

d = 20  
d<sub>1</sub> = 35  
ch = 30  
s = 8,5  
e = 4  
g = 10

**PL 3**

d = 20  
d<sub>1</sub> = 20  
ch = 14  
s = 8,5  
e = 4  
g = 10

**PL 4**

d = 20  
d<sub>1</sub> = 20  
ch = 14  
s = 8,5  
e = 4  
g = 10

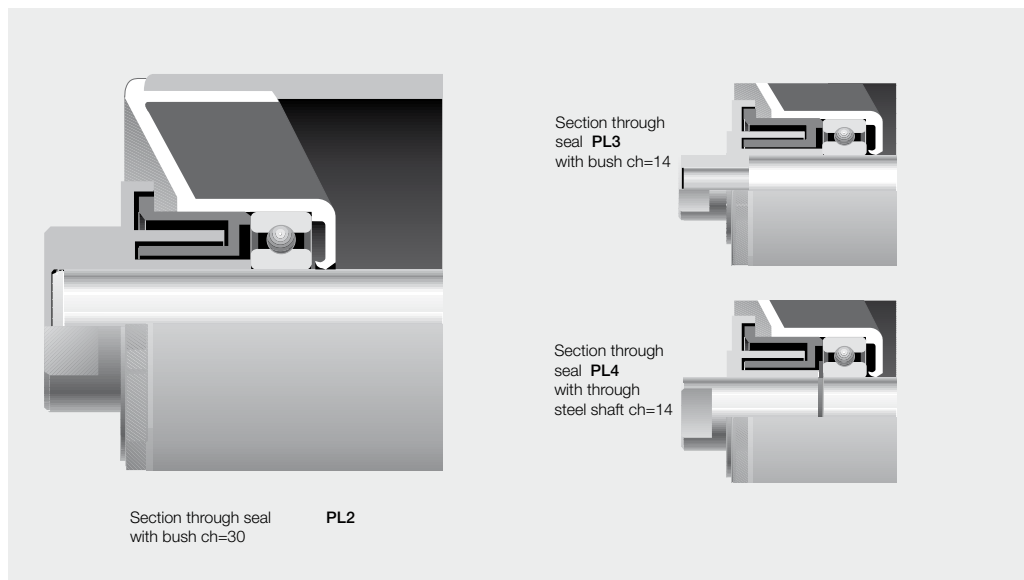

belt	roller										
	width mm	dimensions mm			weight Kg		load capacity daN				
arrangements 	B	C	A	rotating parts		belt speed m/s					
				parts	total	1	1.5	2	2.5	3	4
400	160	168	188	2.3	2.8	120	99	78	76	71	62
500	200	208	228	2.5	3.1	120	99	78	76	71	62
400 650	250	258	278	2.8	3.4	120	99	78	76	71	62
500 800	315	323	343	3.1	3.9	120	99	78	76	71	62
650 1000	380	388	408	3.4	4.4	120	99	78	76	71	62
800 1200	465	473	493	3.8	5.0	120	99	78	76	71	62
400	500	508	528	4.0	5.3	120	99	78	76	71	62
1400	530	538	558	4.1	5.5	120	99	78	76	71	62
500 1000	600	608	628	4.5	6.0	120	99	78	76	71	62
1200	700	708	728	5.0	6.8	120	99	78	76	71	62
650	750	758	778	5.2	7.1	120	99	78	76	71	62
1400	800	808	828	5.5	7.5	120	99	78	76	71	62
800	950	958	978	6.2	8.6	120	99	78	76	71	62
1000	1150	1158	1178	7.2	10.1	120	99	78	76	71	62
1200	1400	1408	1428	8.4	11.9	107	99	78	76	71	62

The indicated load capacity relates to a project working life of 10,000 hours.

**Example of ordering**  
standard design  
PL2,20N,140V,473

for special design  
see pages 80-81

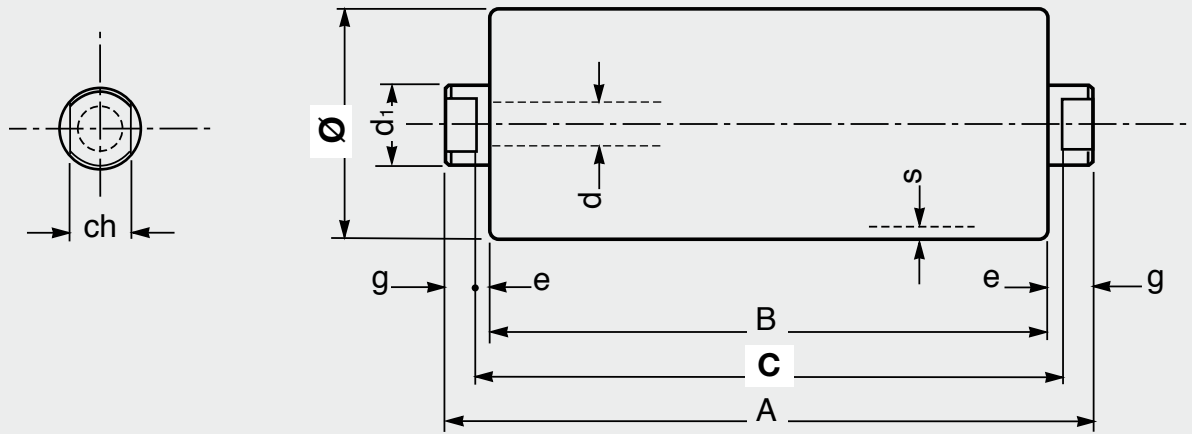



## 2 Rollers

series  
**PLF 1**  
**PLF 5**  
**PLF 20**

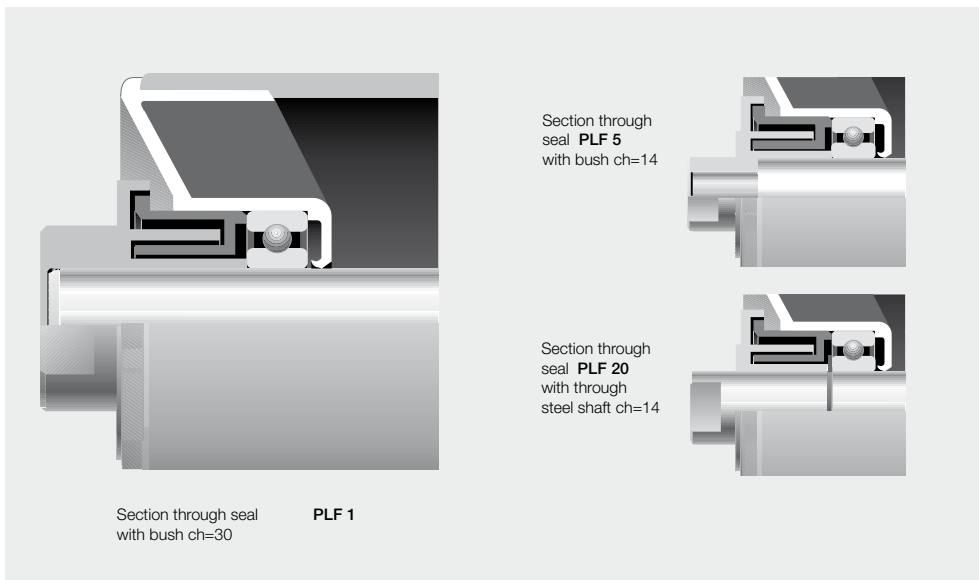

**Ø 89 N**

Bearing 6204  
 (20 X 47 X 14)

### PLF 1

d = 20  
 d<sub>1</sub> = 35  
 ch = 30  
 s = 3  
 e = 4  
 g = 10

### PLF 20

d = 20  
 d<sub>1</sub> = 20  
 ch = 14  
 s = 3  
 e = 4  
 g = 10

### PLF 5

d = 20  
 d<sub>1</sub> = 20  
 ch = 14  
 s = 3  
 e = 4  
 g = 10

belt	roller						load capacity						
	width mm			dimensions mm			weight Kg		daN				
arrangements 	B	C	A	rotating parts		belt speed m/s							
				parts	total	1	1.25	1.5	1.75	2	2.5		
	400	160	168	188	2.3	2.8	129	116	107	99	93	84	
	500	200	208	228	2.5	3.1	129	116	107	99	93	84	
	400 650	250	258	278	2.8	3.4	129	116	107	99	93	84	
	500 800	315	323	343	3.1	3.9	129	116	107	99	93	84	
	650 1000	380	388	408	3.4	4.4	129	116	107	99	93	84	
	800 1200	465	473	493	3.8	5.0	129	116	107	99	93	84	
400		500	508	528	4.0	5.3	129	116	107	99	93	84	
	1400	530	538	558	4.1	5.5	129	116	107	99	93	84	
500 1000		600	608	628	4.5	6.0	129	116	107	99	93	84	
	1200	700	708	728	5.0	6.8	129	116	107	99	93	84	
650		750	758	778	5.2	7.1	129	116	107	99	93	84	
	1400	800	808	828	5.5	7.5	129	116	107	99	93	84	
800		950	958	978	6.2	8.6	129	116	107	99	93	84	
1000		1150	1158	1178	7.2	10.1	117	116	107	99	93	84	
1200		1400	1408	1428	8.4	11.9	96	96	96	96	93	84	

The indicated load capacity relates to a project working life of 10,000 hours.

Example of ordering  
 standard design  
 PLF1, 20N, 89N, 758

for special design  
 see pages 80-81



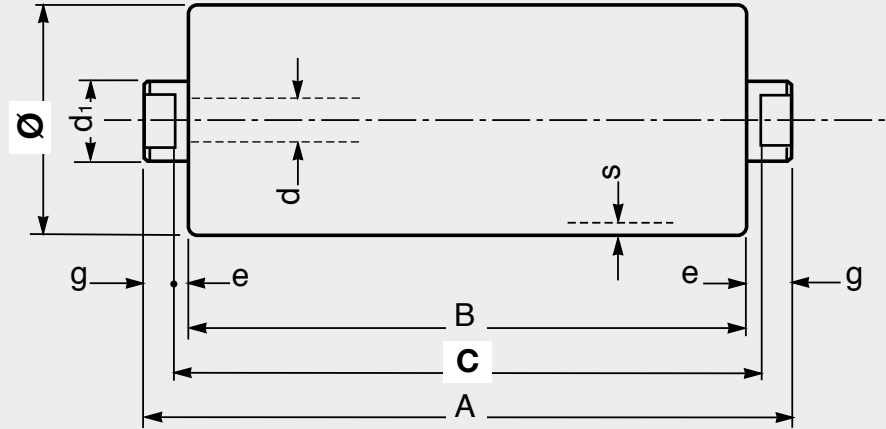
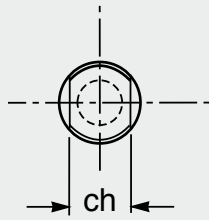

## Ø 108 N

Bearing 6204  
(20 x 47 x 14)

### PLF 1

d = 20  
d<sub>1</sub> = 35  
ch = 30  
s = 3,5  
e = 4  
g = 10

### PLF 20

d = 20  
d<sub>1</sub> = 20  
ch = 14  
s = 3,5  
e = 4  
g = 10

### PLF 5

d = 20  
d<sub>1</sub> = 20  
ch = 14  
s = 3,5  
e = 4  
g = 10

belt	roller			weight		load capacity					
	width mm	dimensions mm			Kg	daN					
arrangements 	B	C	A	rotating		belt speed m/s					
				parts	total	1	1.25	1.5	2	2.5	3
400	160	168	186	2.2	2.7	142	127	117	102	92	84
500	200	208	226	2.6	3.1	142	127	117	102	92	84
400 650	250	258	276	3.0	3.7	142	127	117	102	92	84
500 800	315	323	341	3.6	4.5	142	127	117	102	92	84
650 1000	380	388	406	4.2	5.2	142	127	117	102	92	84
800 1200	465	473	491	5.0	6.2	142	127	117	102	92	84
400	500	508	526	5.3	6.6	142	127	117	102	92	84
500 1000	600	608	626	6.2	7.7	142	127	117	102	92	84
1200	700	708	726	7.1	8.9	142	127	117	102	92	84
650	750	758	776	7.6	9.5	142	127	117	102	92	84
800	950	958	976	9.4	11.8	137	127	117	102	92	84
1000	1150	1158	1176	11.2	14.0	113	113	113	102	92	84
1200	1400	1408	1426	13.4	16.9	93	93	93	93	92	84

The indicated load capacity relates to a project working life of 10,000 hours.

**Example of ordering**  
standard design  
PLF1, 20N, 108N, 958

for special design  
see pages 80-81



## 2 Rollers

series  
**PLF 1**  
**PLF 5**  
**PLF 20**

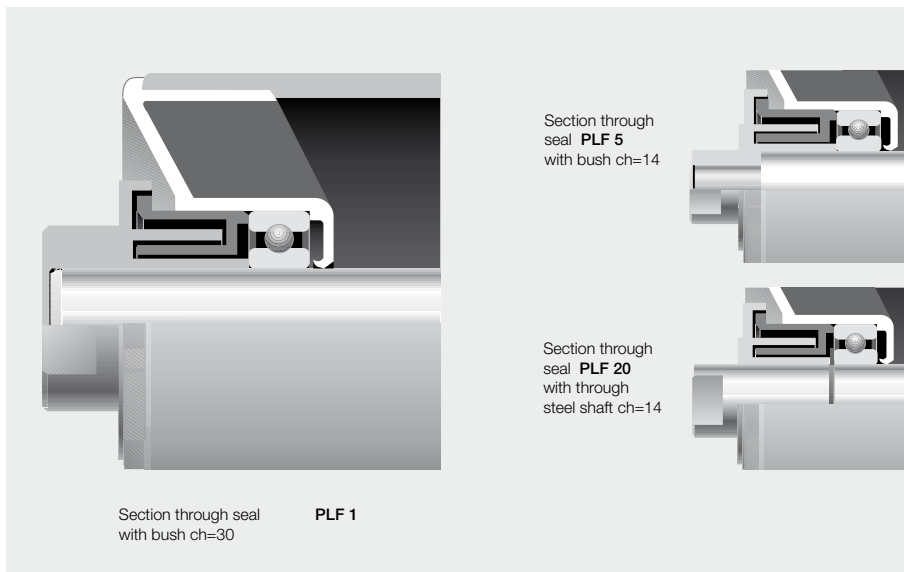

**Ø 133 N**

Bearing 6204  
 (20 x 47 x 14)

**PLF 1**

d = 20  
 d<sub>1</sub> = 35  
 ch = 30  
 s = 4  
 e = 4  
 g = 10

**PLF 20**

d = 20  
 d<sub>1</sub> = 20  
 ch = 14  
 s = 4  
 e = 4  
 g = 10

**PLF 5**

d = 20  
 d<sub>1</sub> = 20  
 ch = 14  
 s = 4  
 e = 4  
 g = 10

belt width mm	roller dimensions mm			weight Kg		load capacity daN					
	B	C	A	rotating parts	total	belt speed m/s					
arrangements 						1	1.5	2	2.5	3	4
400	160	168	186	3.6	4.0	156	129	112	101	93	81
500	200	208	226	4.1	4.6	156	129	112	101	93	81
400 650	250	258	276	4.7	5.4	156	129	112	101	93	81
500 800	315	323	341	5.5	6.4	156	129	112	101	93	81
650 1000	380	388	406	6.4	7.4	156	129	112	101	93	81
800 1200	465	473	491	7.5	8.7	156	129	112	101	93	81
400	500	508	526	7.9	9.2	156	129	112	101	93	81
1400	530	538	556	8.3	9.6	156	129	112	101	93	81
500 1000	600	608	626	9.2	10.7	156	129	112	101	93	81
1200	700	708	726	10.5	12.2	156	129	112	101	93	81
650	750	758	776	11.1	13.0	156	129	112	101	93	81
1400	800	808	826	11.7	13.8	156	129	112	101	93	81
800	950	958	976	13.6	16.0	136	129	112	101	93	81
1000	1150	1158	1176	16.2	19.1	111	111	111	101	93	81
1200	1400	1408	1426	19.4	22.9	91	91	91	91	91	81
1400	1600	1608	1626	21.9	25.9	79	79	79	79	79	79

The indicated load capacity relates to a project working life of 10,000 hours.

**Example of ordering**  
 standard design  
 PLF1, 20N, 133N, 1158

for special design  
 see pages 80-81

